



PROJECT

ITEM NO:

QUANTITY:

Gas Stock Pot Stoves

FEATURES & CONSTRUCTION:

- Stainless steel front and sides, Galvanized steel rear.
- Cast iron 2-ring burner, each 40,000 BTU/hr (Natural Gas)
- Heavy duty cast iron top grate
- Standby stainless steel pilot for easy start
- Adjustable heavy duty stainless steel legs
- Full width stainless steel waste pan at bottom
- Durable brass valve for individual control
- Zinc alloy control knobs
- Easy access to pilot valve with adjustment screws
- Easy gas conversion in field, Conversion kit included.
- 3/4" NPT rear gas connection
- Packaged with carton box, wood strip and with pallet.
- All units shipped K.D., but easily assembled.

MATERIAL:

- Front & Side: Stainless Steel
- Waste Collector: Galvanized Steel plate
- Top Grate: Cast Iron
- Leg: Stainless Steel (1" Adjustable)



Model: SE-SPR1

Model: SE-SPR2



Model #	BTU/HR		Burner Qty	Packing Size	Net Weight	Unit Size			Gas	
	Natural Gas	Propane Gas				W	D	H	Manifold Pressure	Connection
SE-SPR1	80,000	50,000	1	24"x30.3"x20"	103 lbs.	18"	20-7/8"	19-1/2"	Natural Gas: 4" W.C.	3/4"
SE-SPR2	160,000	100,000	2	24"x57"x20"	196 lbs.	18"	41-3/4"		Propane Gas: 10" W.C.	

Refer to owner's manual for complete installation details

Model: SE-SPR1

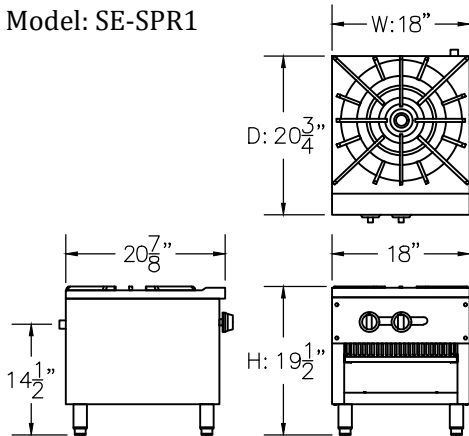

Model: SE-SPR2

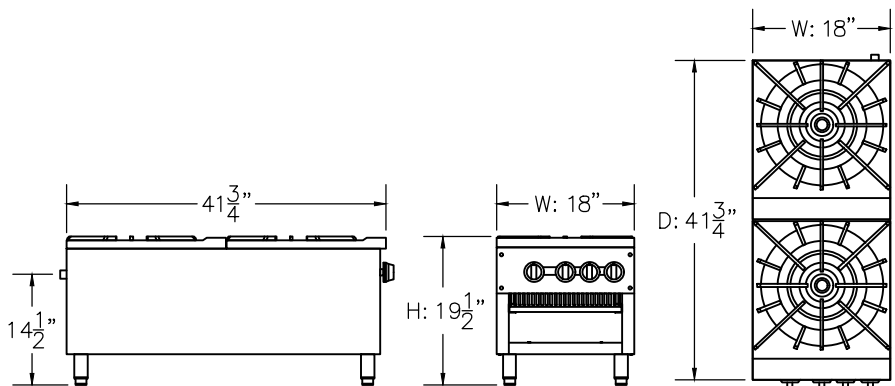

Specifications subject to change without notice.

All dimensions are typical (Tolerance 1/2").



Rev. 06/23

SAPPHIRE MANUFACTURING
Tel: 718-543-2111
Fax: 718-543-2121

info@sapphiremanufacturing.com
WWW.SAPPHIREMANUFACTURING.COM