



PROJECT \_\_\_\_\_

ITEM NO: \_\_\_\_\_

QUANTITY: \_\_\_\_\_

## Gas Convection Oven

### FEATURES & CONSTRUCTION:

- Stainless steel front and galvanized sides with robust support
- Three Direct fired gas burner, each 18,000 BTU/hr.
- Temperature adjustable from 167°F to 563°F
- Porcelainized interior, easy to clean.
- Dual pane thermo glass windows
- 60 minute electric timer with bell
- 1/2 hp fan motor with dual speed control
- Removable 13-position rack guides
- 4 heavy duty chrome plated racks
- Cooling down function
- Interior chamber light
- Double stacking options to optimize kitchen space
- Automatic ignition system for gas safety operation
- Micro switch for complete shut off once door is opened
- Easy gas conversion in field, conversion kit not included.
- 3/4" NPT rear gas connection
- 4 Swivel casters with brake included
- Packaged with carton box, wood strip and with pallet.
- All units shipped K.D., but easily assembled.



Model #	Total BTU/HR	Packing Size	Net Weight	Gross Weight	Unit Size			Gas		Electrical	
					W	D	H	Manifold Pressure	Connection	115V 1ph 60hz	6' Cord NEMA 5-15 Plug
SE-CO1D	54,000	46"x42"x42"	408 lbs.	606 lbs.	38"	43-3/8"	54-1/2"	Natural Gas: 4" W.C. Propane Gas: 10" W.C.	3/4"		

Refer to owner's manual for complete installation details

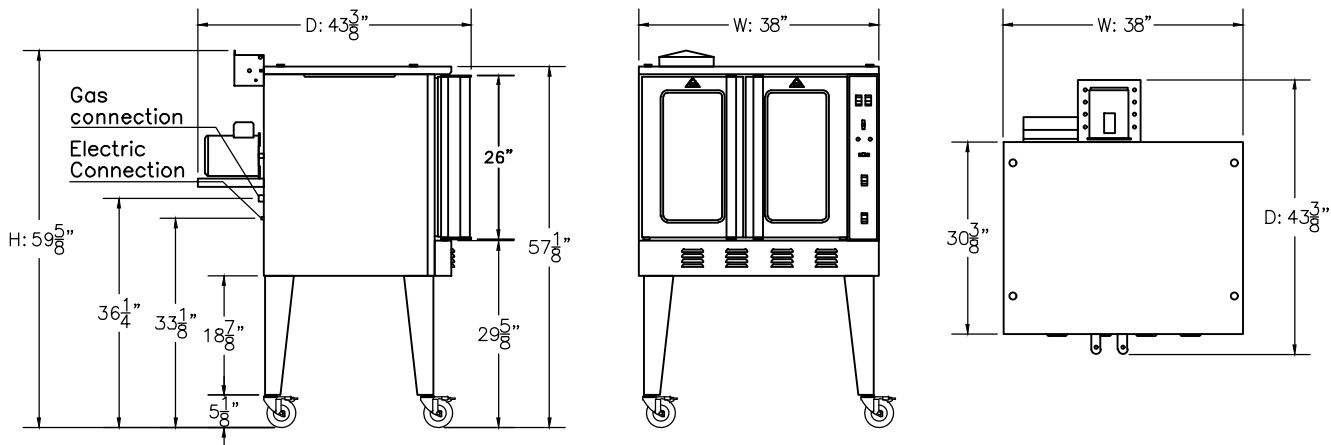

Specifications subject to change without notice.

All dimensions are typical (Tolerance 1/2").



**SAPPHIRE MANUFACTURING**  
 Tel: 718-543-2111  
 Fax: 718-543-2121

[info@sapphiremanufacturing.com](mailto:info@sapphiremanufacturing.com)  
[WWW.SAPPHIREMANUFACTURING.COM](http://WWW.SAPPHIREMANUFACTURING.COM)

Rev. 06/23