



PROJECT

ITEM NO:

QUANTITY:

Equipment Stand

Galvanize Steel Undershelf Series



NSF Certified

FEATURES & CONSTRUCTION:

- Top is fabricated with 1-1/2" rounded front edges and 2" high splash guard at rear and both sides.
- Table front edge formed with hemmed edges to provide extra rigidity and safe to touched finished.
- Reinforced table top with sound deadened hatch channels.
- Adjustable undershelf secure to leg with aluminum die cast clamp.
- All exposed welded areas smooth polished to brush finish sanitary #4.
- Welded leg socket for removable table legs.
- All tables shipped K.D. and easily assembled.

MATERIAL:

TOP: 16 Gauge Stainless Steel - 400 series
 SHELF: 18 Gauge Galvanized Steel
 LEG: 1 5/8" Galvanized Steel Tubing, Galvanized Steel Leg Socket, 1" Adjustable Plastic Bullet Feet.



SMES-2448G

MODEL#	SIZE		
	D	L	H
SMES-2412G	24"	12"	24"
SMES-2418G		18"	
SMES-2424G		24"	
SMES-2430G		30"	
SMES-2436G		36"	
SMES-2448G		48"	
SMES-2460G		60"	
SMES-2472G		72"	
SMES-3012G	30"	12"	24"
SMES-3018G		18"	
SMES-3024G		24"	
SMES-3030G		30"	
SMES-3036G		36"	
SMES-3048G		48"	
SMES-3060G		60"	
SMES-3072G		72"	
SMES-3084G		84"	
SMES-3096G		96"	

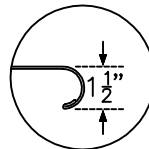

Rolled Rim Edge
 Front And Rear
 Reinforced with
 Hemmed Edge

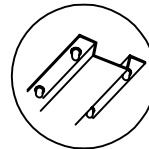

Hatch Channel
 Supported

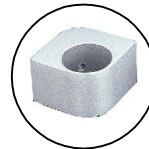

Aluminum Die Cast
 Clamp For Adjustable
 Under Shelf



Plastic Bullet Feet
 1" Adjustable



SMES-3084G



SAPPHIRE MANUFACTURING
 Tel: 718-543-2111
 Fax: 718-543-2121

info@sapphiremanufacturing.com
 WWW.SAPPHIREMANUFACTURING.COM

Rev. 11/16



PROJECT _____

ITEM NO: _____

QUANTITY: _____

Equipment Stand

Galvanize Steel Undershelf Series



NSF Certified

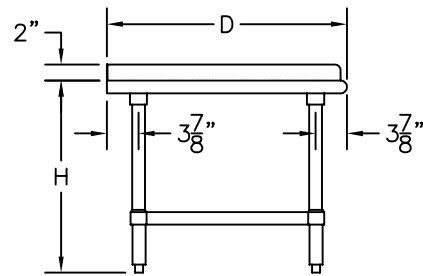
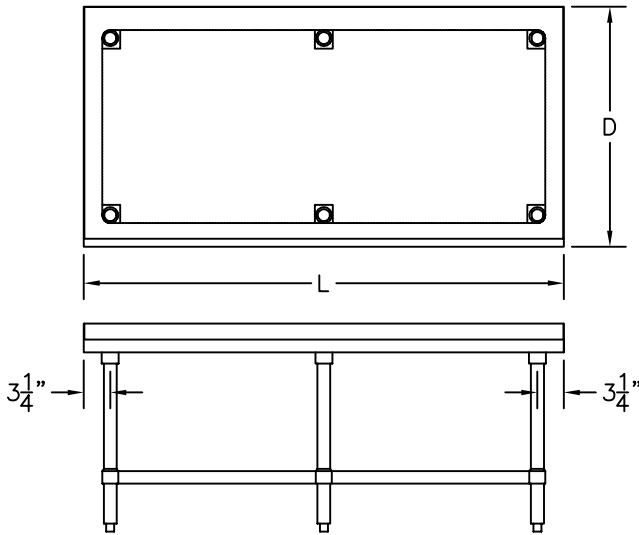
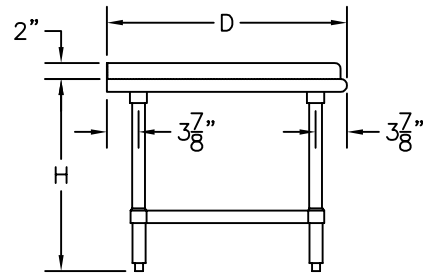
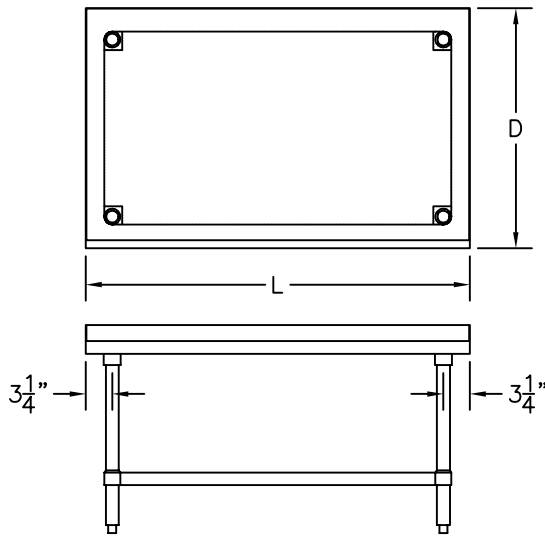

* 60" and longer come with 6 legs

Specifications subject to change without notice.

All dimensions are typical (Tolerance 1/2").



SAPPHIRE MANUFACTURING
Tel: 718-543-2111
Fax: 718-543-2121

info@sapphiremanufacturing.com
WWW.SAPPHIREMANUFACTURING.COM

Rev. 11/16